

A photograph of an offshore wind turbine platform mooring connect (PMC) in the ocean. The structure consists of two yellow cylindrical buoys connected by a yellow metal walkway. A white wind turbine is mounted on the left buoy. The background shows a clear blue sky and a distant coastline with hills.

*FirstSubsea*

# Platform Mooring Connect (PMC)

Daniel Giddings

Senior Engineer

# First Subsea



- Established in 1994, over 30 years supplying class leading products to the offshore oil, gas and renewable industries
- First Subsea's expertise are built around a drive for engineering excellence, demonstrated by our capabilities in design, engineering, analysis and project management.

- | Design, engineering and analysis
- | Project Management
- | Procurement and PU manufacture
- | Inspection and assembly
- | Component and system testing

## Equipment Supply

Rental and supply of mooring products and solutions, lifting equipment, subsea connectors, and offshore products

**First Subsea**  
**1<sup>ST</sup> INTEGRATED**  
LIFTING | INSPECTION | RENTALS

**MOORING SYSTEMS**

**FMS**  
FIRST MARINE SOLUTIONS  
For the Mooring Systems

**NSC** | NORTH SEA COMPACTORS

**TUSK**  
LIFTING





# PMC – Sizes



To optimise the design and cost the PMC is standardised into three MBL series:

- **S1 — 750 tonne MBL**
- **S2 — 1,300 tonne MBL**
- **S3 — 2,000 tonne MBL**

Standardising the PMC into three load classes provides several advantages:

- **Reduced bespoke engineering**
- **Predictable performance envelopes**
- **Manufacturing efficiency**
- **Simplified platform integration**
- **Supply-chain scalability**



# PMC – Components – Assembly



Foundation Bracket

Connecting Link

Receptacle Assembly

Male Assembly

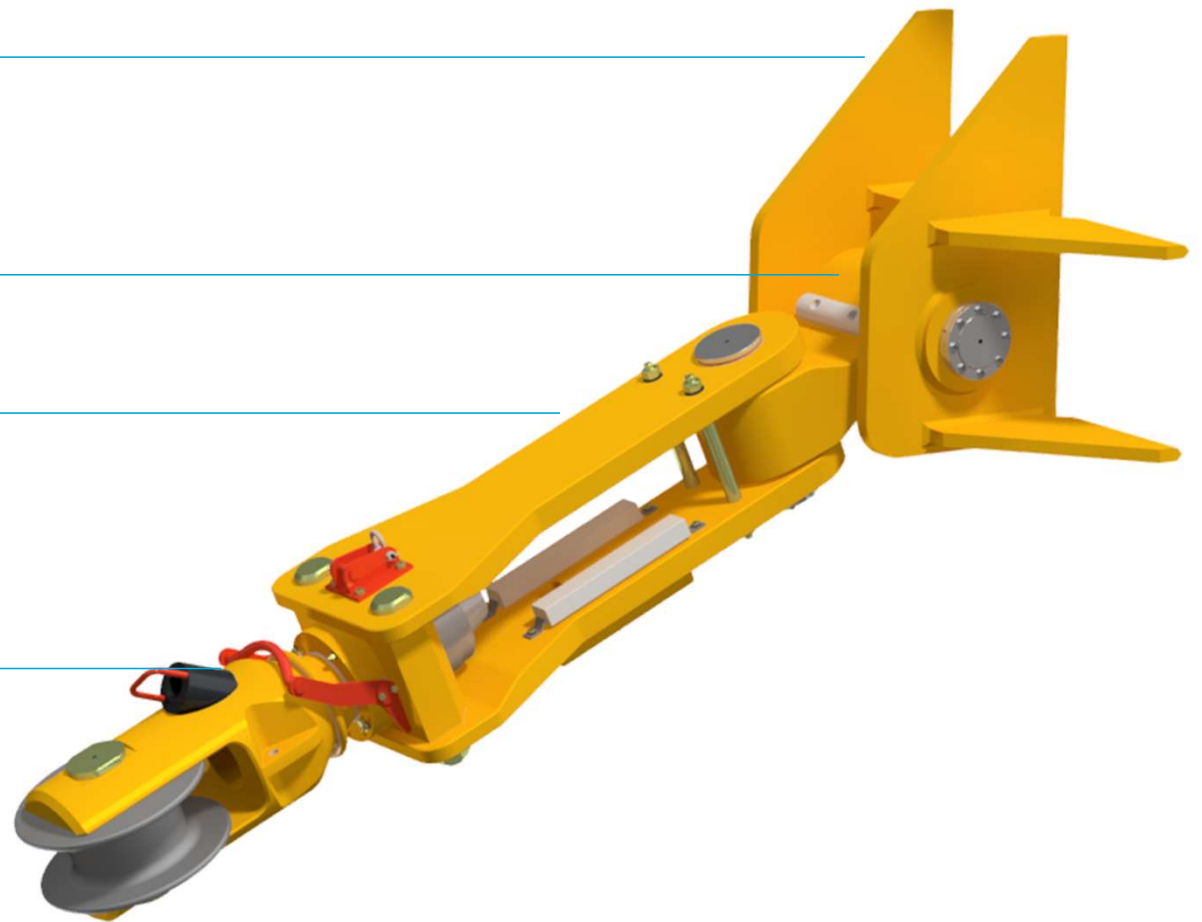

*FirstSubsea*

# PMC – Components – Male



- Grooves for interface with the receptacle
- Termination of messenger line at the front of the male for easy access
- Mooring line interface
- Additional features



*FirstSubsea*

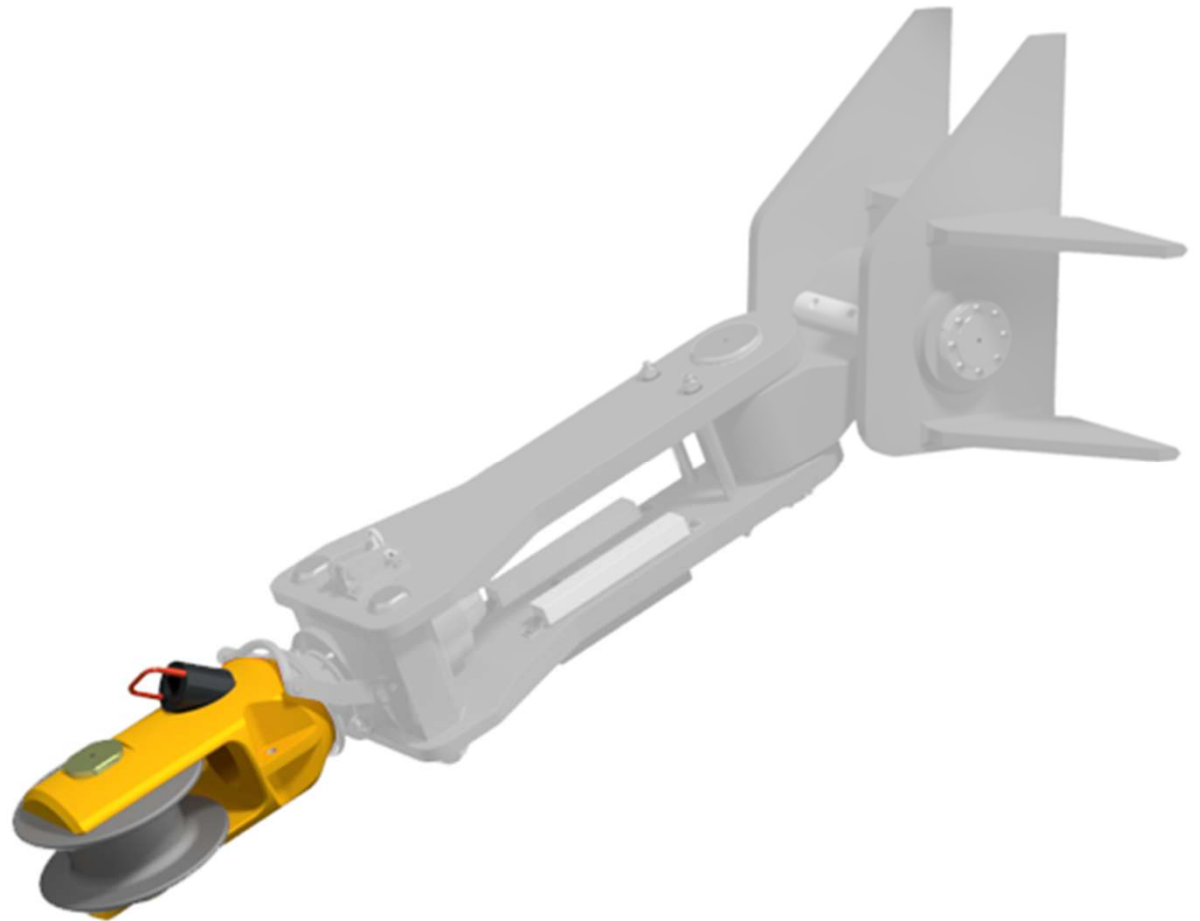

# PMC – Components – Receptacle



- Quick connect latching gripping element for interface with the male
- Open design to allow easy access to various parts of the connector
- Dedicated anodes for cathodic protection
- Interface for hydraulic release tool

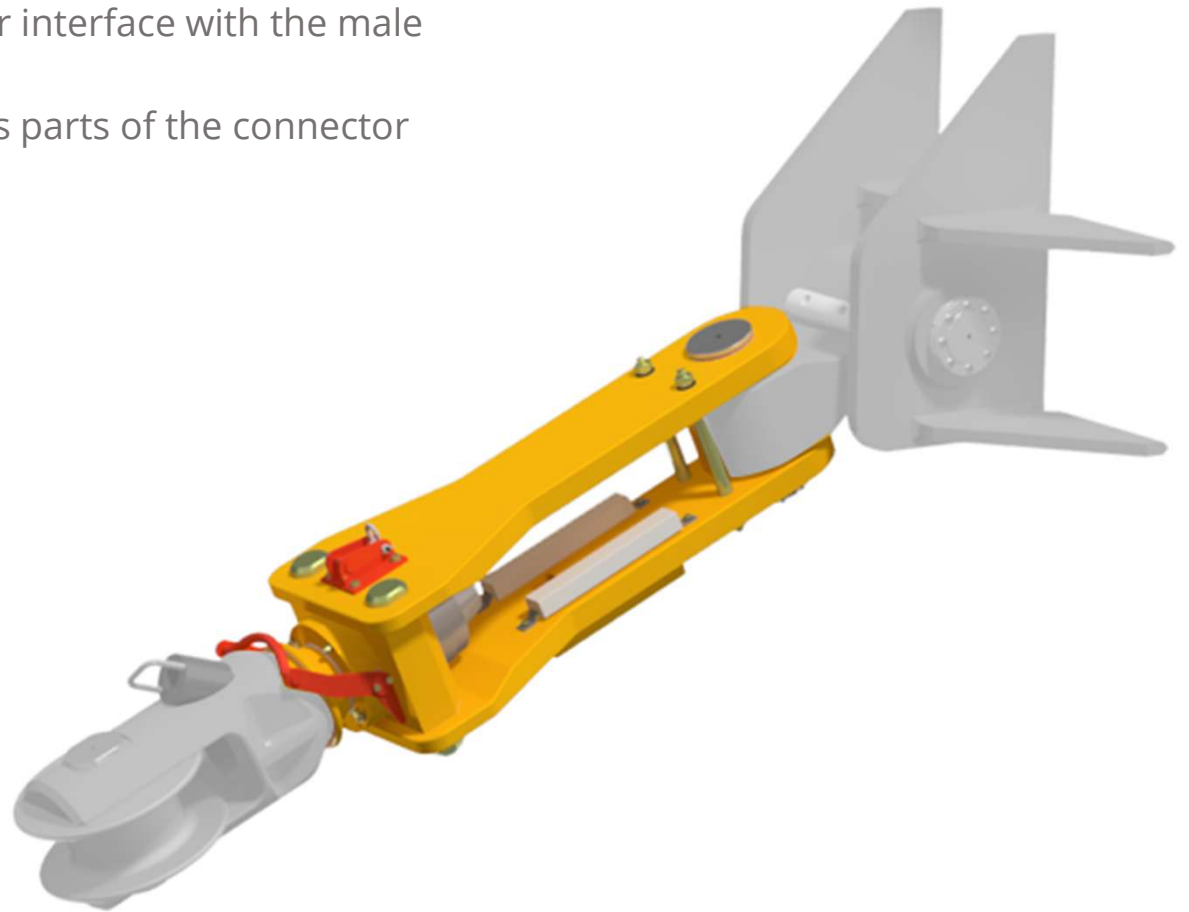

# PMC – Components – Receptacle



- Client driven additional features

- Diverter Sheave

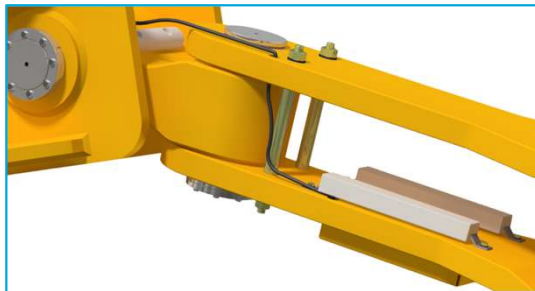

- Monitoring



- Secondary Lock

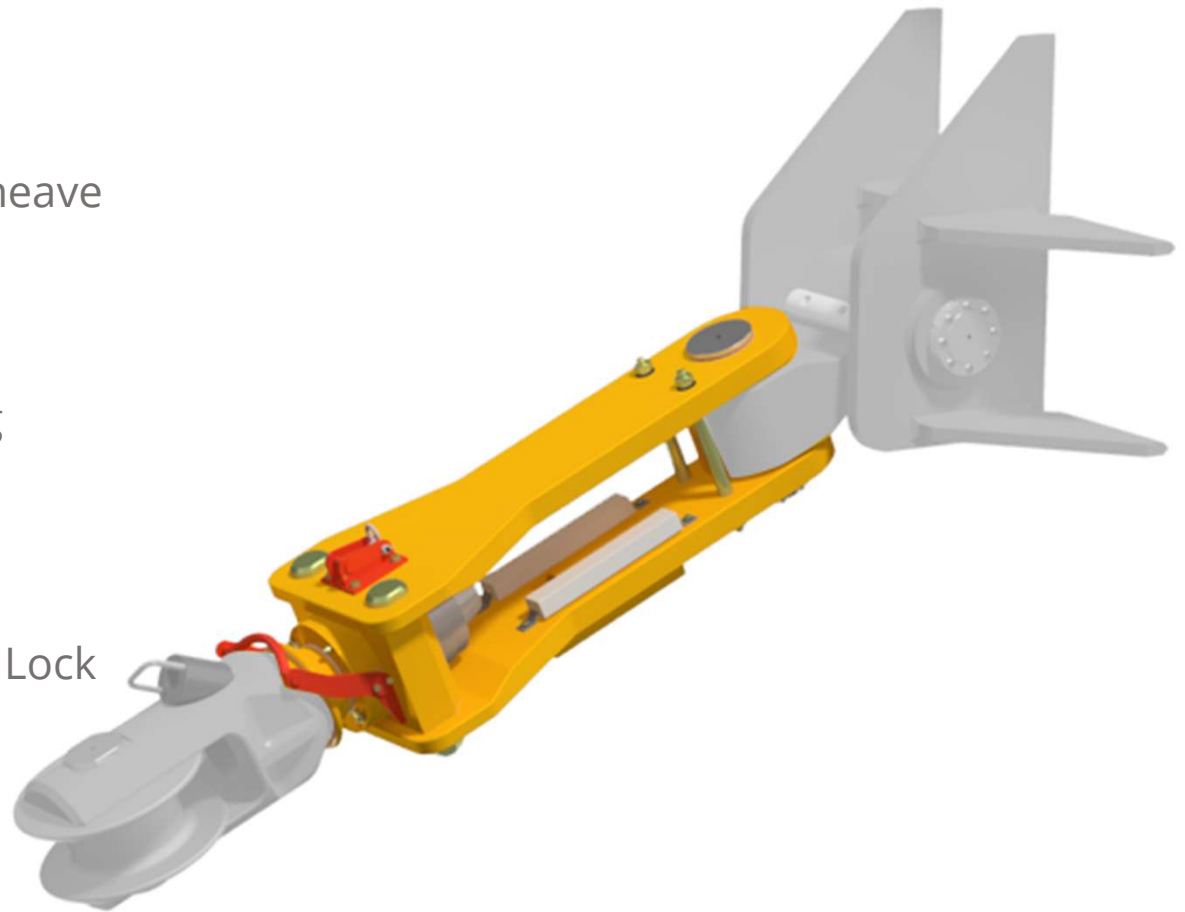

*FirstSubsea*

# PMC – Components – Connecting Link



- Super Duplex pins to provide the bearing strength and corrosion protection required
- Water lubricated bushings/bearings for both axis' of movement
- Design to provide the degrees of freedom
- Dedicated anodes for cathodic protection
- Pull in features as required

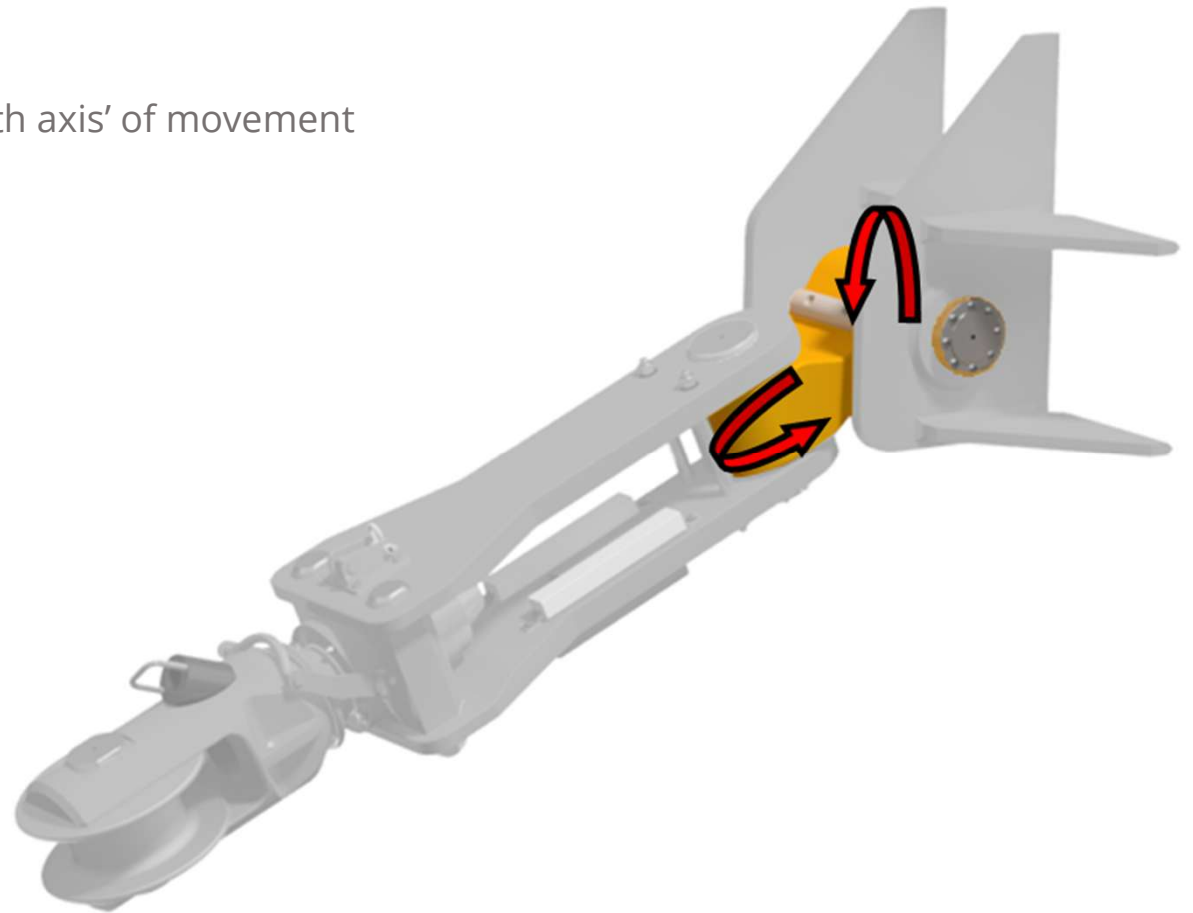

# PMC – Components – Connecting Link



The connecting link design is dictated by the mooring arrangement:

- 3 lines (Kincardine & Windfloat)
  - *In the event of a mooring line failure, the structure can move off location significantly, this means:*
    - *The mooring arrangement changes*
    - *The connecting link movement range is significant*

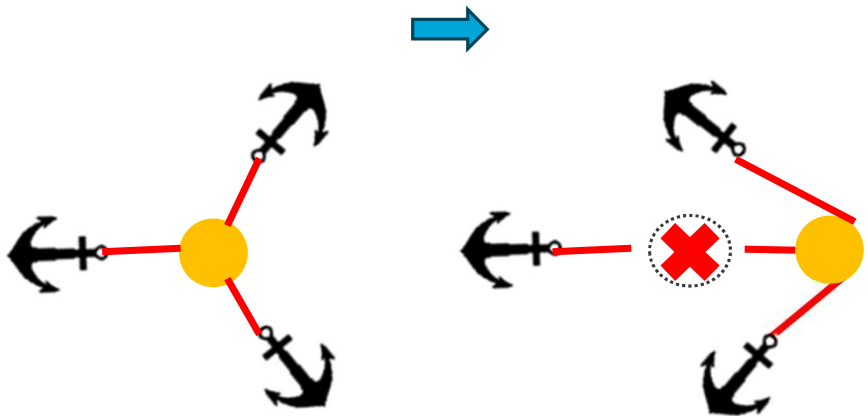

*FirstSubsea*

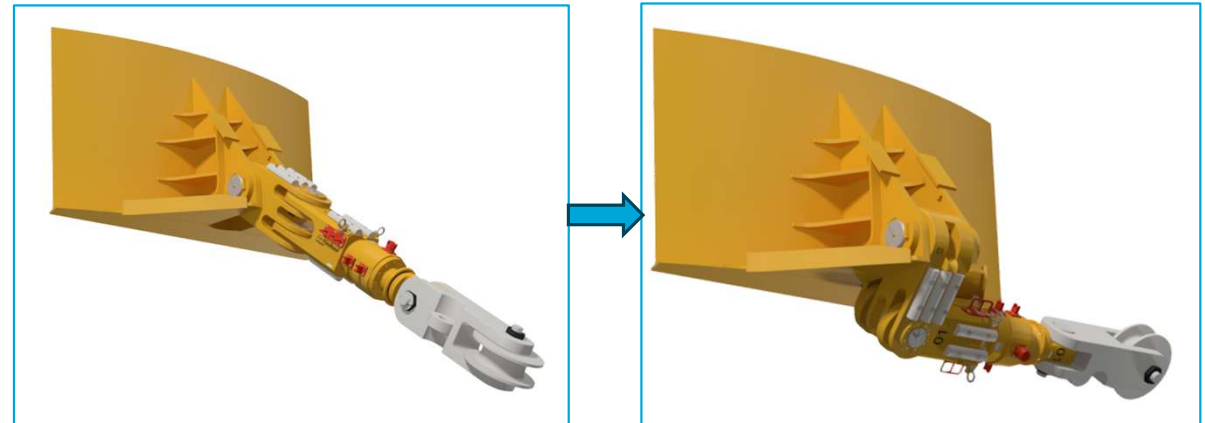

# PMC – Components – Connecting Link



- 6+ lines
  - *Single line failure increases loads, but arrangement remains the same*
    - *Smaller ranges of movement*
    - *Simpler connecting link design*

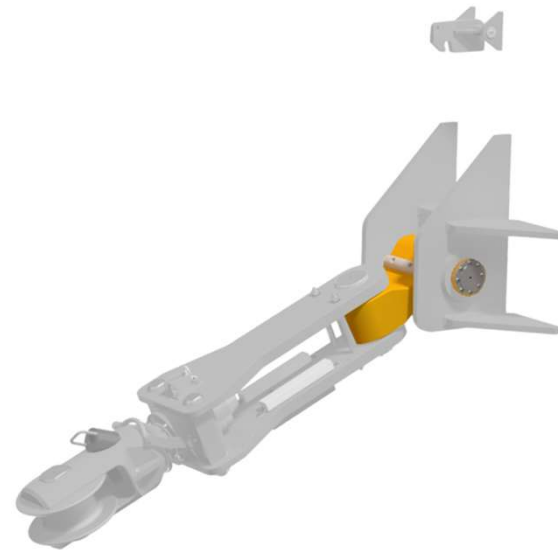
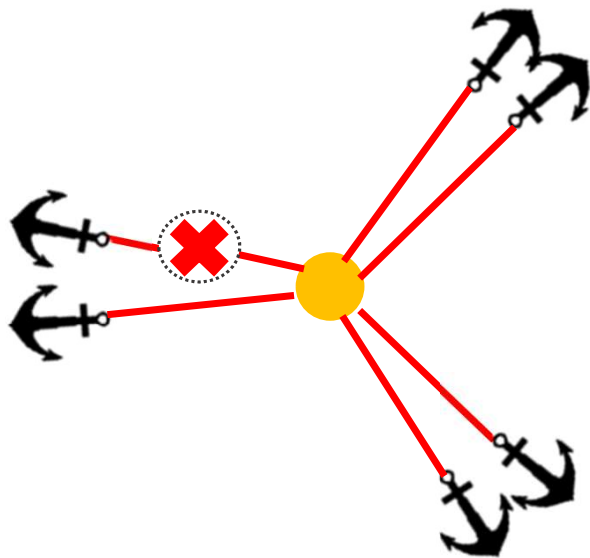

# PMC – Components – Bracket



The foundation bracket is a simple fabrication that provides the interface for the receptacle connecting link.

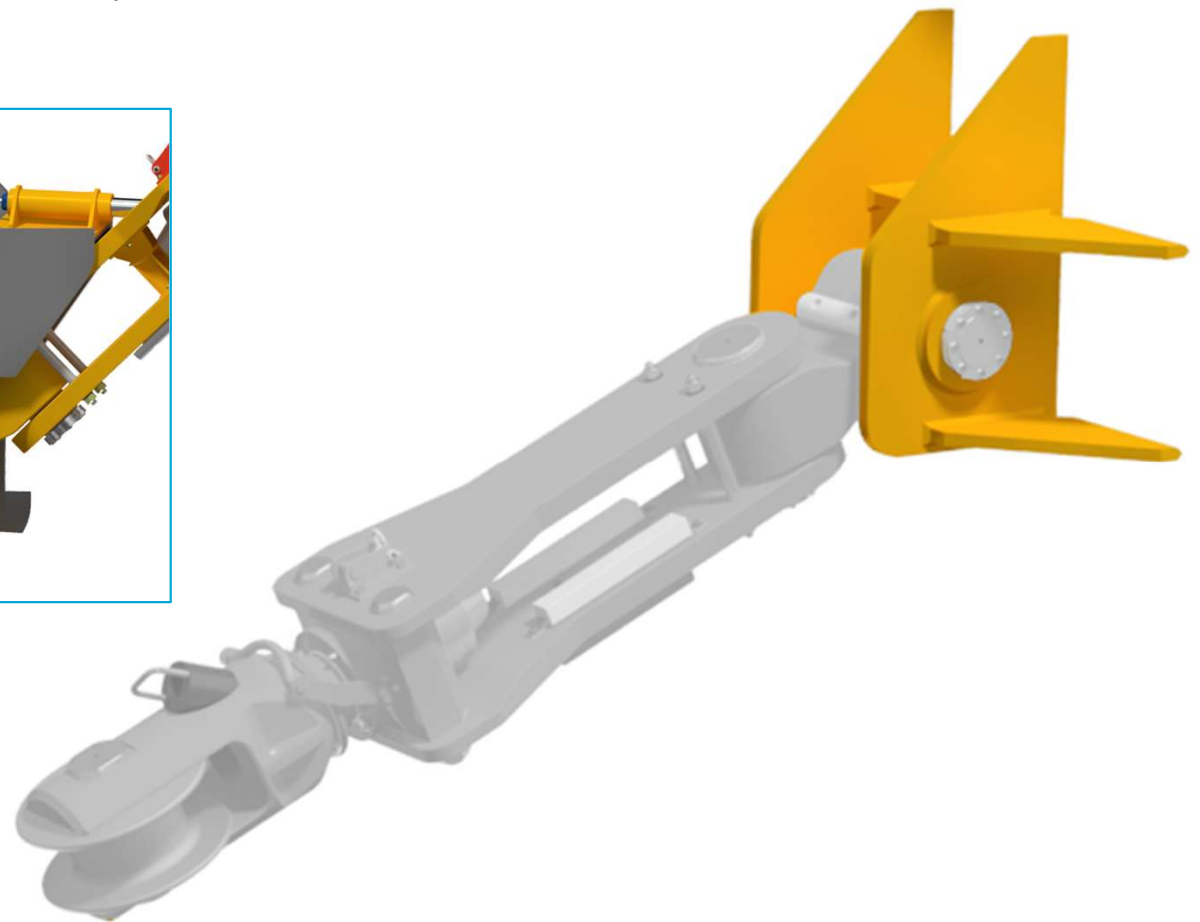
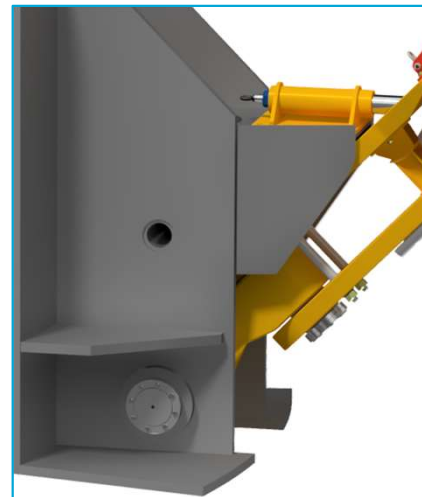

*FirstSubsea*

# PMC – Ball Gripping



- Optimum geometry on mating parts
- Positive connection
- Sprung engagement – failsafe
- Minimal force to disengage

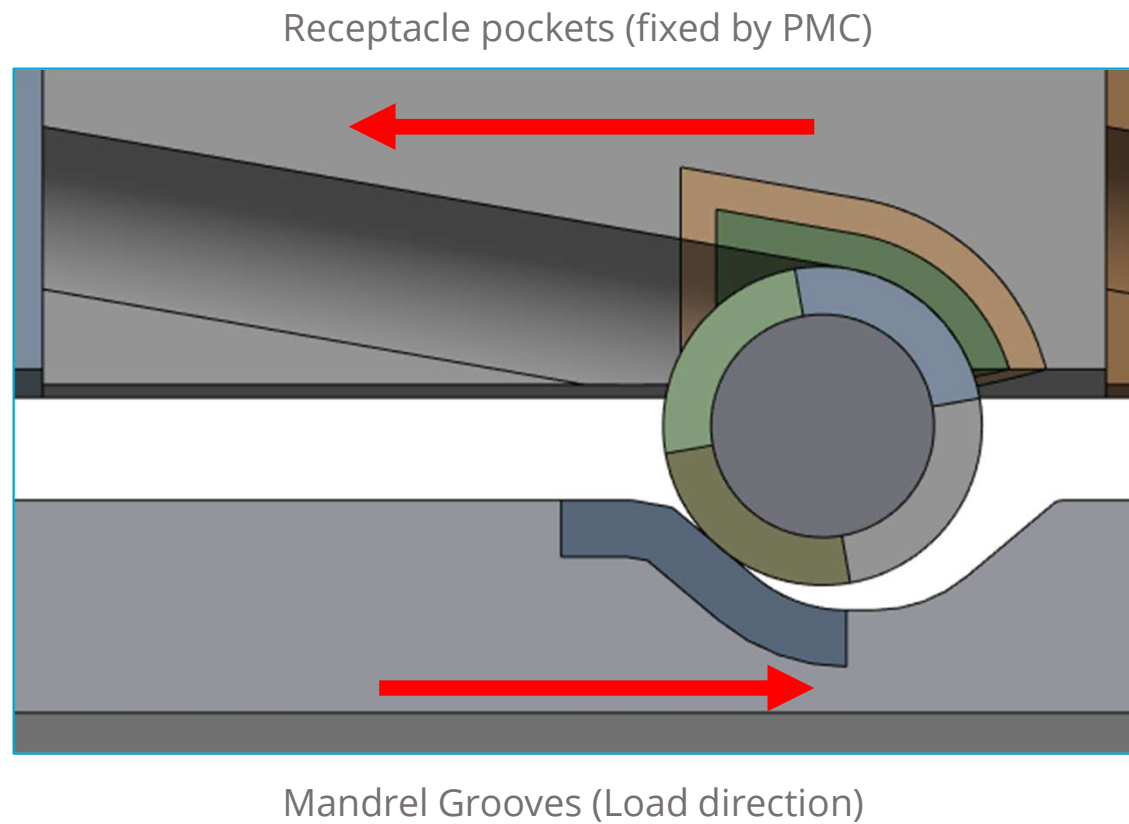

# PMC – Projects

---



## WindFloat Atlantic

- Project: 3 x WindFloat platforms equipped with 8MW turbines
- Location: Atlantic Ocean
- PMC Qty: 9 x Platform Mooring Connectors (PMC) +1 MBL unit as per ABS requirements
- Design Life: 25 years
- MBL: 560 tonne
- Installation date: Aug 2019 – Dec 2019

## Kincardine

- Project: 5 x WindFloat platforms equipped with 9.5MW turbines
- Location: North Sea
- PMC Qty: 15 x Platform Mooring Connectors (PMC) +1 MBL unit as per ABS requirements
- Design Life: 25 years
- MBL: 750 tonne
- Installation date: Nov 2020 – May 2021



# PMC – Installation



- Winch line to platform
- 1<sup>st</sup> and 2<sup>nd</sup> mooring legs pulled in at low line tension
- 3<sup>rd</sup> mooring leg requires vessel to allow low tension pull in
- Vessel pulls the platform towards 3<sup>rd</sup> mooring leg

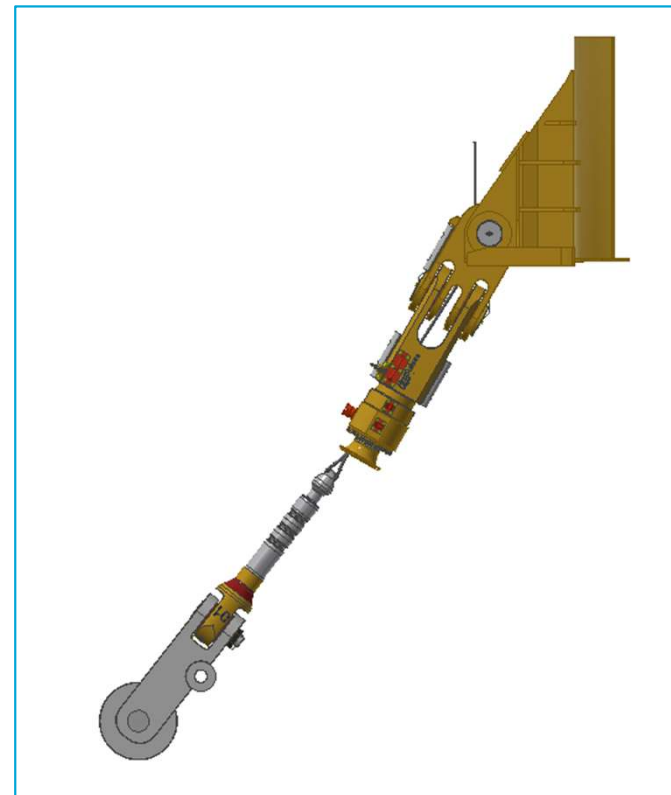
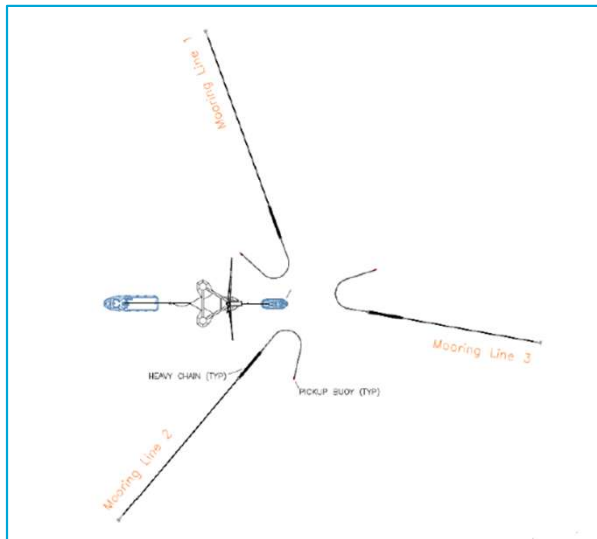

# PMC – Installation

- Mooring line with male PMC typically pre-laid on the seabed
- Receptacle PMC held in a vertical position during tow out
- Receptacle PMC lowered and messenger line handed over
- Mooring line pulled in until male PMC connects to receptacle
- No intervention required during the pull in

*FirstSubsea*

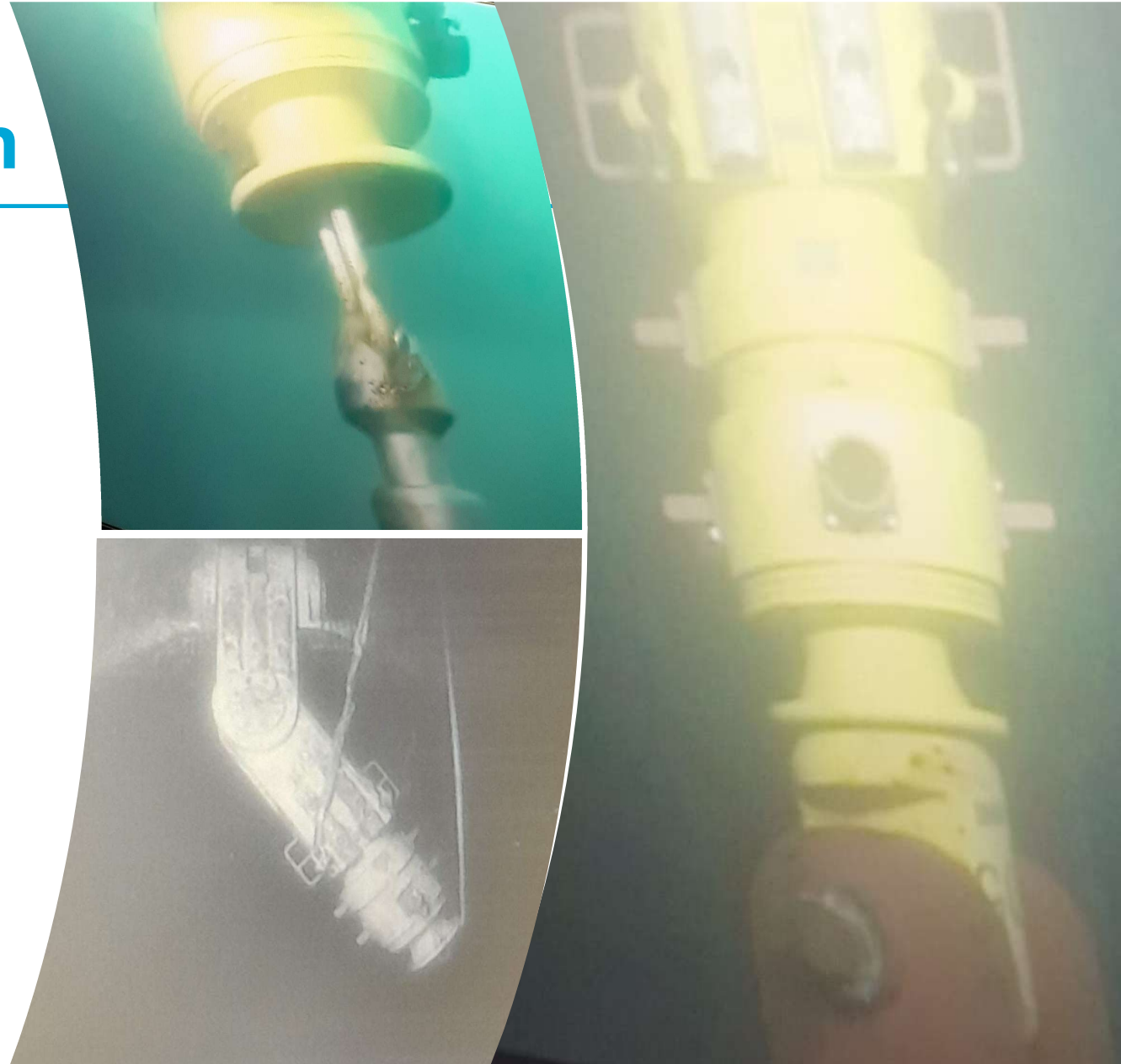

# PMC – Installation Times

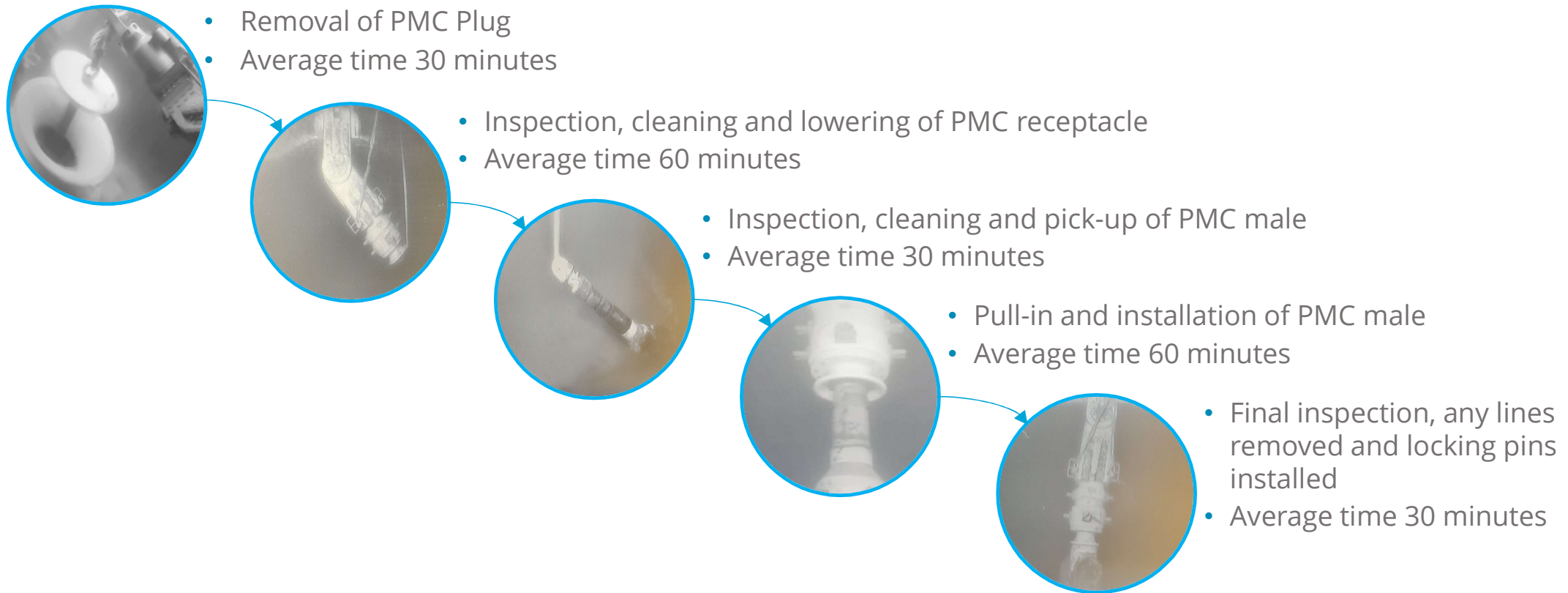

# PMC – Disconnection

---

- Visual inspection and light water jetting with ROV to remove marine growth and ensure smooth operation
- Secondary lock removed if applicable
- Hydraulic release tool (HRT) placed onto receptacle PMC by ROV.
- HRT actuated either by ROV, diver or piped directly topside to the floater or vessel
- Male PMC lowered out of receptacle

*FirstSubsea*



# PMC – Re-Connection

- Male PMC can be laid on the seabed while the floater gets towed to port
- Floater gets towed to site after maintenance
- Mooring lines get picked up and pulled in, no requirement for the PMC male to interface with the original PMC receptacle
- No intervention required, instantaneous storm safe connection

*FirstSubsea*



# PMC – Cobra Wind - Project



- Overview

- *The project consists of an array of five WindFloat platforms equipped with 9.5MW Vestas V164 turbines with a design life of 25 years*
- *Each of the five platforms will be anchored to the seabed with three catenary mooring lines*

Description	Value
Design loads	7500 kN corroded (MBL test load) end of life
Design life	25 years
Declination range	-40° to 80°
Azimuth range	±90°
PMC water depth	10 to 20m

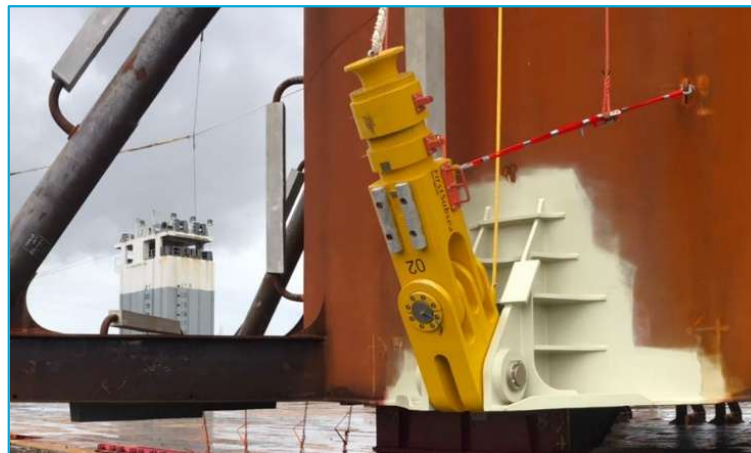
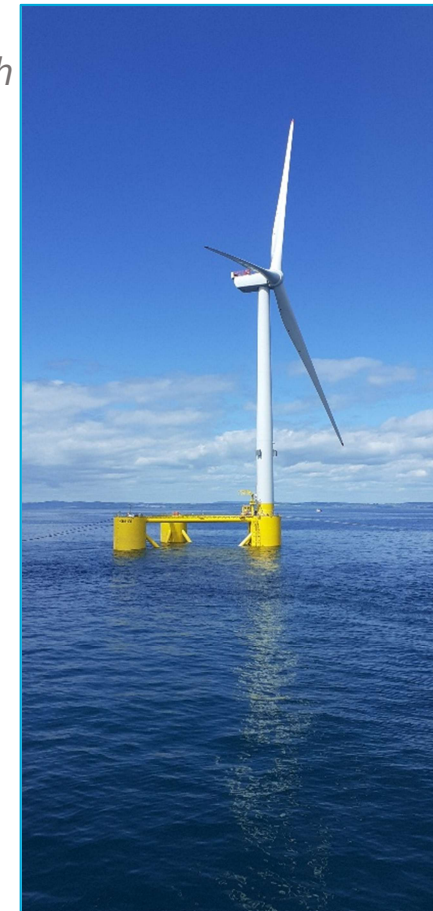

# PMC – Cobra Wind - Loading



Load Cases	Description	Max Tension (kN)	Azimuth Range (deg)	Declination Range (deg)
Load Case 1	MBL	7500	N/A	N/A
Load Case 2	Operating in 1yr storm	2782	±50	10 to 60
Load Case 3	Parked in 50yr storm	3560	±50	5 to 70
Load Case 4	Parked in 500yr storm	5585	±65	0 to 80
Load Case 5	Damaged and Parked in 50yr storm	3680	±90	-40 to 65

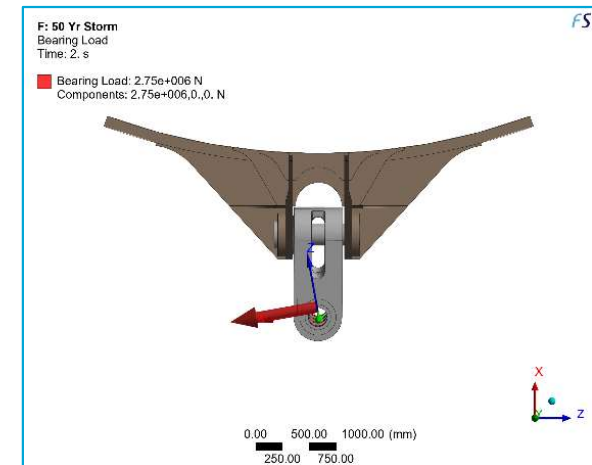
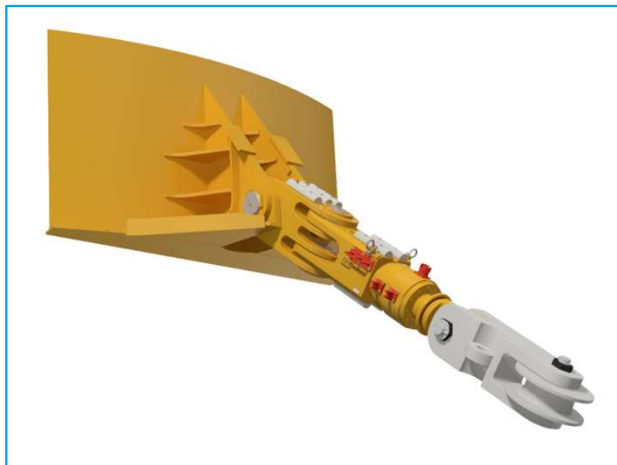

FirstSubsea



# PMC – Cobra Wind - Standards



- Key standards for design
  - *DNV-OS-E301 – Position mooring*
  - *DNV-OS-E302 – Offshore mooring chain / ABS – Guide for the certification of offshore mooring chain*
  - *DNV-RP-C203 – Fatigue design of offshore steel structures*
  - *BV-NR445-B – Rules for the classification of offshore units / BV-NR493 – Classification of Mooring Systems for Permanent*
- Other standards for project
  - *ABS Rules for Materials and Welding Part 2*
  - *API RP 2SK - Design and Analysis of Stationkeeping Systems for Floating Structures*
  - *ASTM A370 - Standard Test Methods and Definitions for Mechanical Testing of Steel Products*
  - *BS EN ISO 13628-1 Petroleum and Natural Gas Industries – Design and Operation of Subsea Production Systems*



# PMC – Cobra Wind - FEA



- For the PMC the overall assembly has been split into four analyses

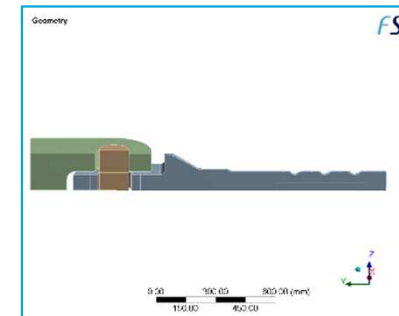
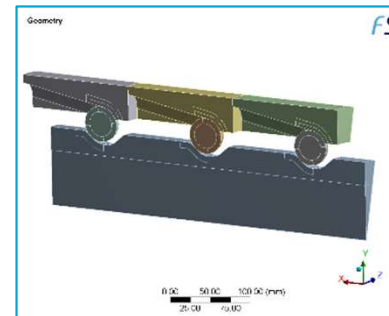
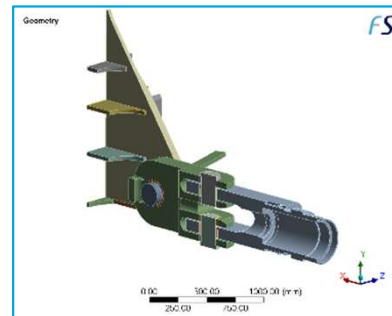
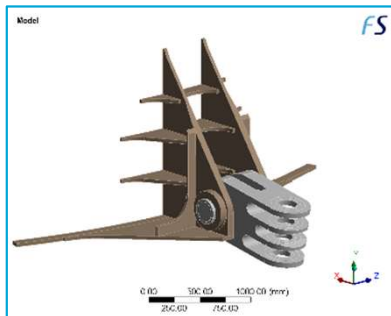

- Why use FEA
- Analysis with criteria per DNV-OS-E301
- Material models

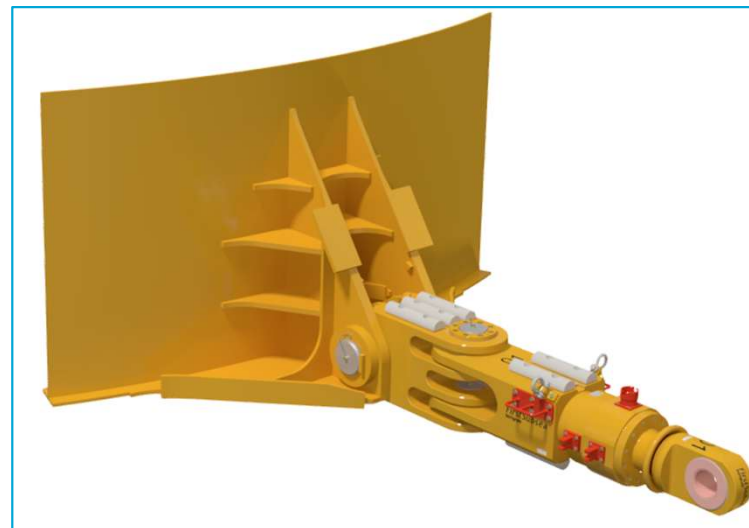

# PMC – Cobra Wind - FEA



- Analyses show stress concentrations as would be expected
  - PMC Connecting Link
  - PMC Receptacle Assembly
  - PMC Gripping Mechanism
  - PMC Male

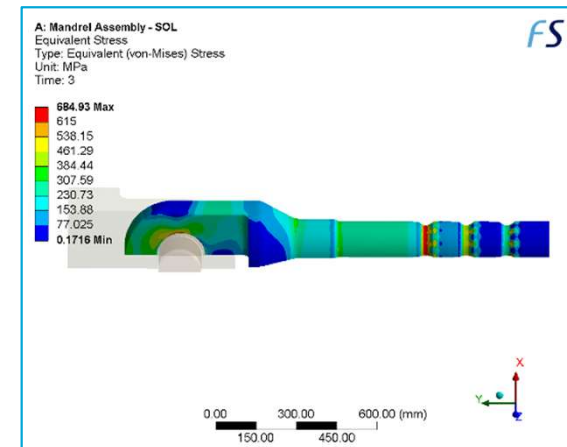
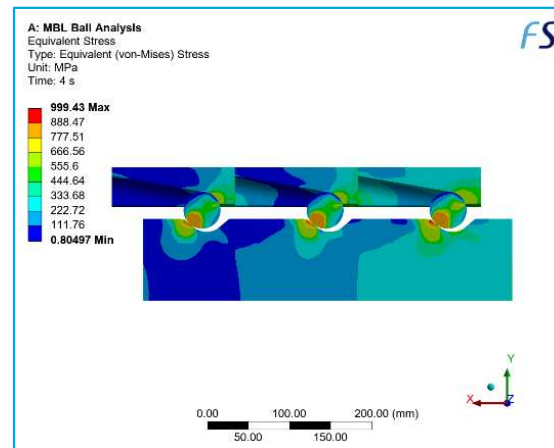
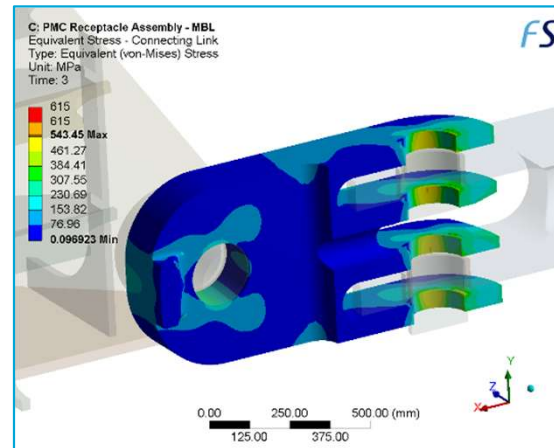
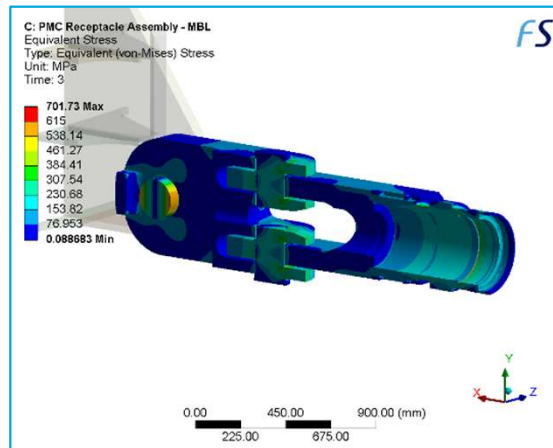

# PMC – Cobra Wind - Fatigue



- The FEA gives a maximum principal stress for each component allowing fatigue calculation

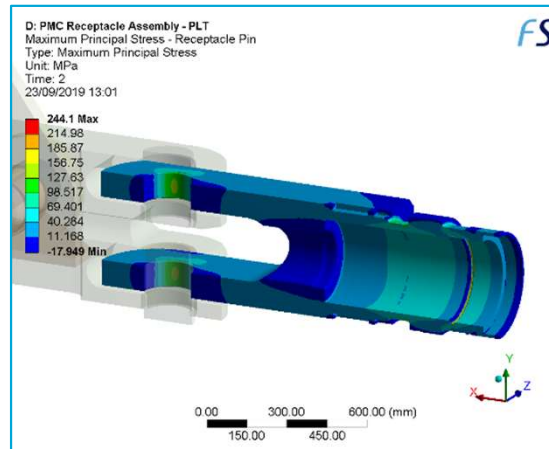
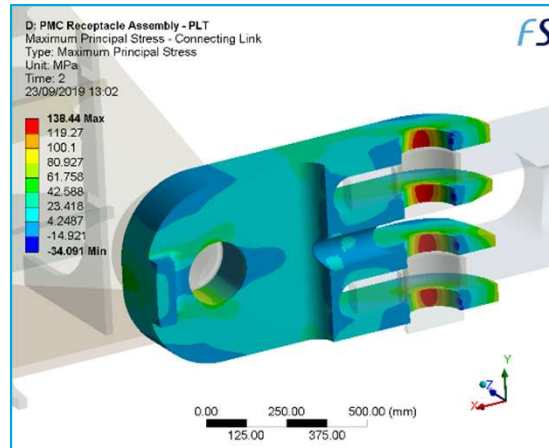
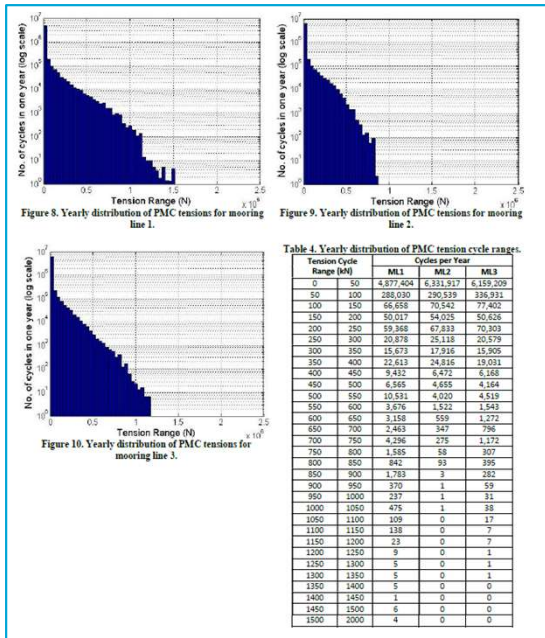

General Information	
Works Order	WO19836 - Kincardine PMC
Item	Receptacle
Item State	Uncorroded (Corrosion Protected)
Data Type	Peak Tension Range
Fatigue Standard	DNVGL-RP-C203 Fatigue Design of offshore steel structures

Inputs from FEA model	
Maximum principal stress (MPa)	244.10
Tension load applied for full model (kN)	2000

Fatigue Parameters - B1 - Curve			
Basic S-N Curve parameters		Thickness Correction Parameters	
a	14.917	t <sub>ref</sub>	N/A
m	4	t	N/A
a2	17.146	k	N/A
m2	5		

Life Parameters - Taken from customer specification	
Fatigue Design Life	25
Design Fatigue Factor	10

Results	
Damage due to tension over one year	5.62005E-05
Damage due to tension over design life	0.001405012
Total life of tool in years	711.7

$$\log N = \log \bar{a} - m \log \left( \Delta \sigma \left( \frac{t}{t_{ref}} \right)^k \right)$$



# PMC – Cobra Wind – Cathodic Protection



- The PMC is designed to sustain 25 years operation in shallow water.
- Electrical insulation bushing and washers are fitted between H-Link/Mandrel Connector, Connecting Link/Receptacle Connector and Connecting Link/Hull Structure to isolate each component for CP purposes

Description	Corrosion Protection	
	Primary	Secondary
External Components	Cathodic Protection	Coatings
Internal Components	Deoxygenation	Coatings



# PMC – Cobra Wind – Materials



- All major items on load path are forged to grade R3S with 3.2 certification
- Balls machined from bar



# PMC – Cobra Wind – ABS Assessment



- ABS approval (3.2 Certification)

**FirstSubsea**

First Subsea Ltd.  
Engineering House, Lane Industrial Estate,  
New Quay Road, Lancaster, LA1 5QP, UK  
Tel: +44 (0)1524 387 777 Fax: +44 (0)1524 387 778  
www.firstsubsea.com

**Proof Load Test Register  
19836 TR 007**

Project:	Kincardine Offshore Wind Project	Customer:		W/O No:	19836
Project Manager:	Ian Jowett	Contact:		P/O No:	KIN-CN-PU-CON-0100
Test Procedure:	19836-P-T-PR-001	Revision:	A	Test Lead:	
				Date of Test:	15/07/2020

Test Ref	FS Serial No. FS-19836-PMC	FS Serial No. FS-19836-PMC	FS Serial No. FS-19836-PMC	FS Serial No. FS-19836-PMC	FS Serial No. FS-19836-PMC	Req'd Test Load KN	Req'd Test Pressure Bar	Actual Test Pressure Bar	Start Time	Peak Load Time	Finish Time
PL#16	-ME-14	-FE-14	-CL-06	-RP-04 & 16	-CP- 12	5913	142	145	09:47	09:50	09:50
MBL	-ME-14	-FE-14	-CL-06	-RP-04 & 16	-CP- 12	7500	180	183	09:50	09:52	09:53

- Equipment used during test:
- 2 off 15 000KN cylinders, serial numbers: FSC.CYL.700BAR-28, FSC.CYL.700BAR-29
  - 0355.1 analogue gauge, 0355.2 analogue gauge.

The above test parameters have been checked and verified that they fulfil the contract design criteria:  
Design Engineer: Tony Little Sign: *Tony Little* Date: 15/07/2020

Proof Load Witness Test Signatories: We confirm that the test performed as above were completed as per the associated test procedure and witnessed:

Company Stamp <i>[Signature]</i> Lead Test Engineer First Subsea Ltd Name: Mike Harney Date: 15/07/2020	Company Stamp <i>[Signature]</i> Project Manager First Subsea Ltd Name: Ian Jowett Date: 15/07/2020	Company Stamp <i>[Signature]</i> Design Engineer First Subsea Ltd Name: Tony Little Date: 15/07/2020	Company Stamp <i>[Signature]</i> Client Inspector Company: Name: Date:	Company Stamp <i>[Signature]</i> 3 <sup>rd</sup> Party Inspection Authority Company: ABS Name: Ian Harnwell Date: 15/07/2020 # 4123145
--	--	---	---	--

QF121C Rev A; Dated: 07-Feb-2014

Drawing No.	Rev. No.	Title	Status
147215	A	Mandrel	Approved <sup>1</sup>
147876	B	Receptacle	Approved <sup>1</sup>
147877	B	Connecting Link	Approved <sup>1</sup>
147879	A	Receptacle Pin	Approved <sup>1</sup>
148492	A	Connecting Link Pin	Approved <sup>1</sup>
149508	A	Receptacle Pin Forging	Approved <sup>1</sup>
--	-	Installation and Disconnection Procedure stage 3 and 4	Filed for reference
KIN-NA-SPE-PP-007	00	LTM Platform Mooring Connectors Specifications	Filed for reference
3019	A	Standard Anode Type 128ZHD and 51XHD	Filed for reference
147205	A	Locking Ring	Filed for reference
147210	B	Mandrel Assembly	Filed for reference
147214	B	Mandrel Assembly With H-Link	Filed for reference
147890	B	Platform Mooring Connector Overall GA	Filed for reference
147962	A	Gripping Mechanism Assembly	Filed for reference
147975	B	Receptacle Workshop Assembly	Filed for reference
148495	A	Connecting Link Pin Assembly	Filed for reference
149434	B	Receptacle Assembly	Filed for reference
149533	B	Platform Interface to PMC	Filed for reference
149991	B	Connecting Link Assembly	Filed for reference
KIN-EM-RPT-FS-0005	A	FEA & Fatigue Report (PMC) Ball Gripping Mechanism	Reviewed
KIN-EM-RPT-FS-0004	A	FEA & Fatigue Report (PMC) Mandrel Assembly	Reviewed
KIN-EM-CAL-FS-0003	A	Anode Calculation Connecting Link	Reviewed
KIN-EM-RPT-FS-0003	A	FEA & Fatigue Report (PMC) Connecting Link	Reviewed
KIN-EM-CAL-FS-0002	A	Anode Calculation Mandrel and Receptacle Assemblies	Reviewed
KIN-EM-RPT-FS-0002	A	FEA & Fatigue Report (PMC) Receptacle Assembly and Connecting Link	Reviewed
KIN-EM-CAL-FS-0001	A	Design Calculations	Reviewed
KIN-EM-RPT-FS-0001	A	Design Report (PMC)	Reviewed

Notes: <sup>1</sup>Approved subject to conditions given in Page 1 of this letter.

**FirstSubsea**



# PMC – Development



- Receptacle change to structural plates from forged body
  - *Conforms with DNV-ST-0119*
  - *Reduced cost*
  - *Reduced lead time*
- Receptacle change to gripping mechanism
  - *Single forged part from multiple rings*
  - *Modified disconnection reducing length*
  - *Leads to shorter more compact male*
- Fabrication of connecting link
  - *Easier access*
  - *Reduced cost*
  - *Reduced lead time*

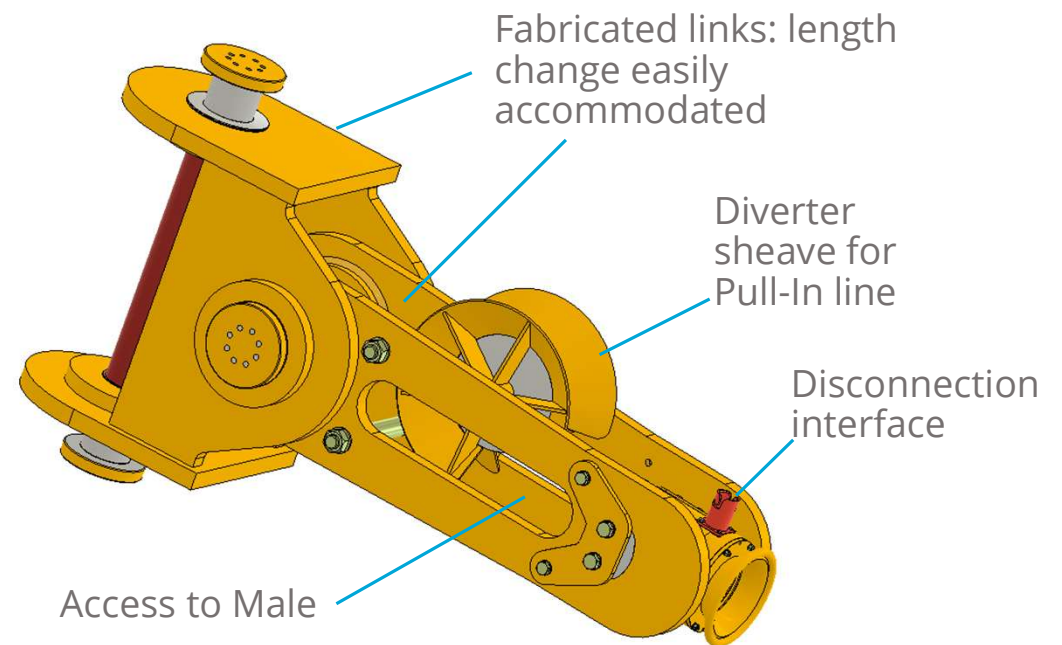



First Subsea, Engineering House, Lune  
Industrial Estate, New Quay Road,  
Lancaster, LA1 5QP, UK